



Creating the Next Internet Revolution

Supply Chain Connectivity from Conception to Consumption

John Eul

October 23, 2001





auto-id center

vision, technology, applications



overview

- About the Center
- Vision
- Technology
- Example applications
- Timings
- Options for participation
- Questions



about the center

- Global, industry funded research program
Massachusetts Institute of Technology (1999)
Cambridge University (2000)
Labs planned for Asia (2001) & South America (2002)
- Mission
Change the world by merging bits and atoms



about the center

- End User Sponsors

- Procter & Gamble, Gillette, Uniform Code Council (UCC), CHEP, International Article Numbering Association (EAN), International Paper, Philip Morris Group, Johnson & Johnson, Wal-Mart, Yuen Foong Yu, United States Postal Service, Westvaco, Unilever, Kimberly-Clark

- Vendor Sponsors

- NCR, Savi Technologies, Sun Microsystems, Flint Ink, Markem, Invensys, Sensormatic, Cash's, Rafsec, Flexchip, Alien Technology, Philips Semiconductor, SAP

- Trade Bodies

- AIM Global, GCI, GMA, FMI, NACS, NACDS, AIM, POPAI, IMRA, ARTS, UTSA



vision

- A world where...
 - ...bits and atoms are merged
 - ...physical objects communicate in real time all the time
 - ...the Internet extends into everyday products
 - ...everything is connected



why atoms matter

- Atoms matter because...
 - ...you can't eat bits
 - ...human beings are made of atoms
 - 'and will be for the foreseeable future'
 - ...exchange of atoms ('trade') is the root of all commerce



networks of bits and atoms

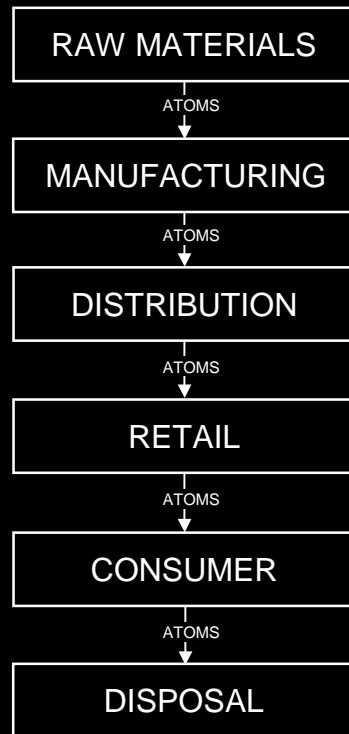

The supply chain is a network of atoms



networks of bits and atoms

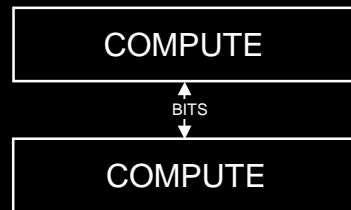

The Internet is a network of bits



networks of bits and atoms

E-commerce links the networks

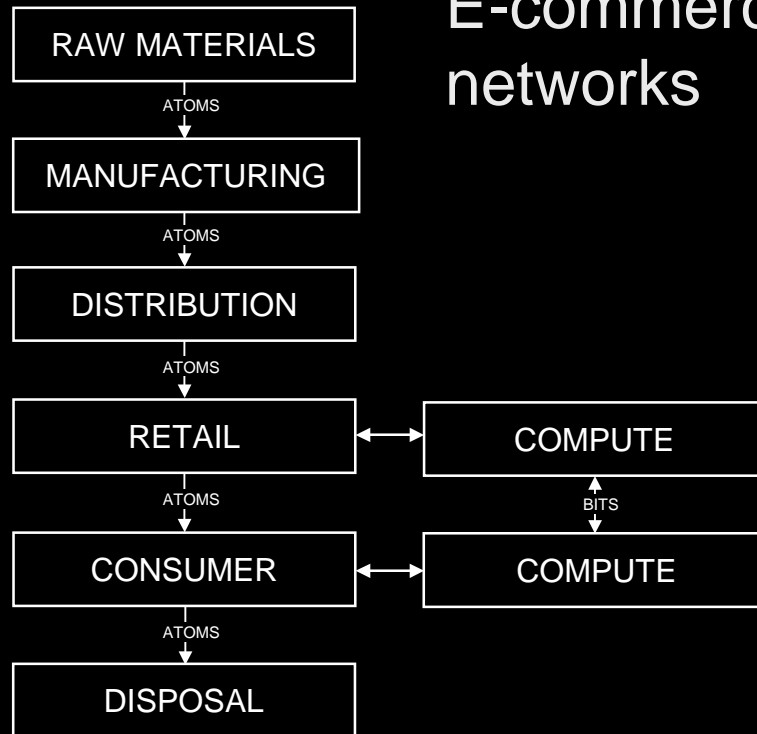



networks of bits and atoms

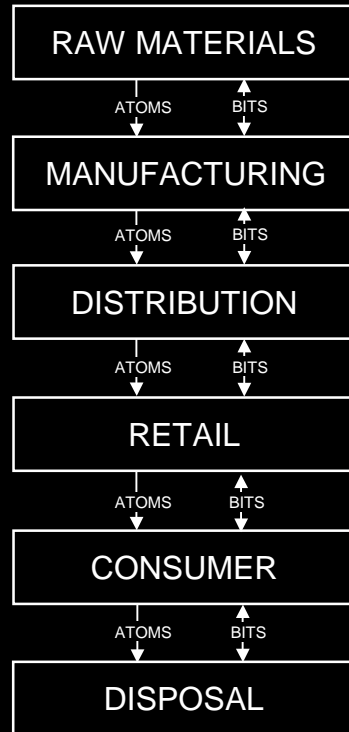

We aim to merge them



technology

- What do you need to merge bits and atoms?
 - ...a single system for the whole supply chain
maybe as many as 10^{16} objects
 - ...smart scalable networking for the physical world
 - ...computers that can make decisions on their own



technology

...a single system for the whole supply chain

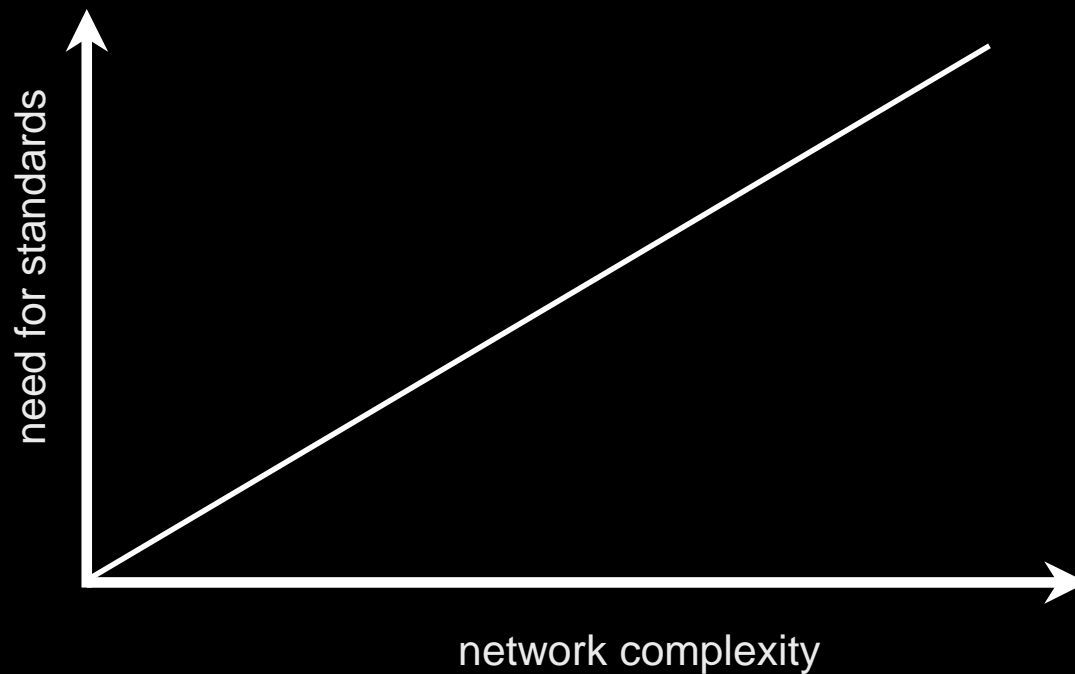



technology

...smart scalable networking for the physical world

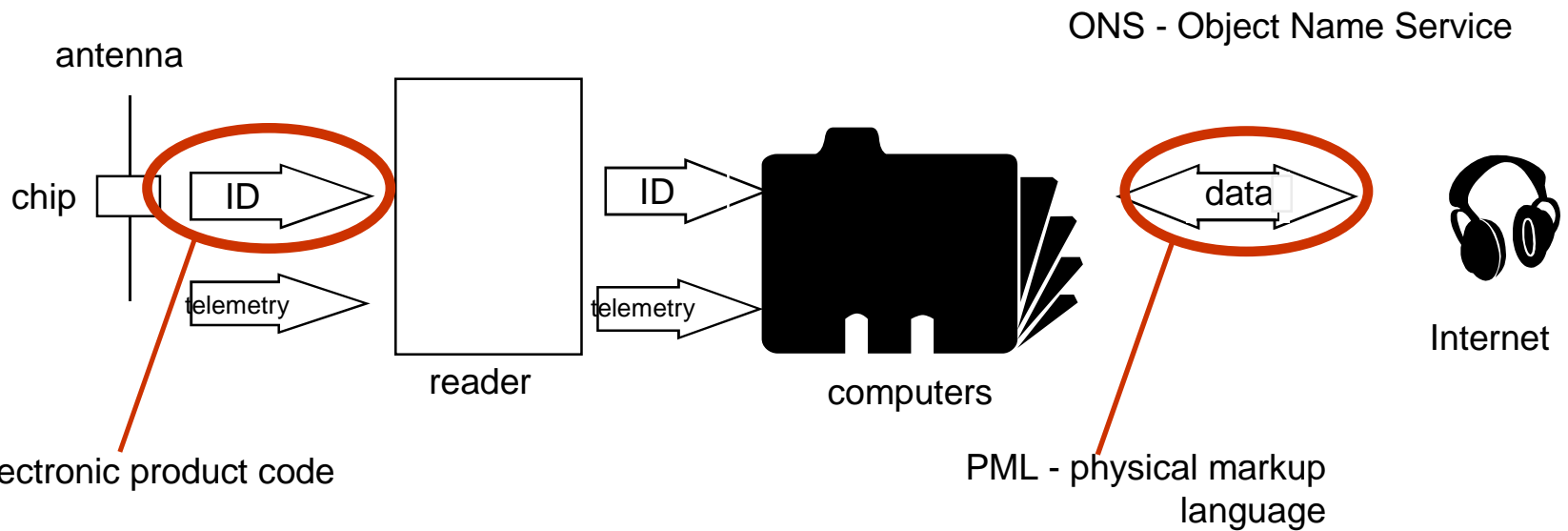



technology

...computers that can make decisions on their own

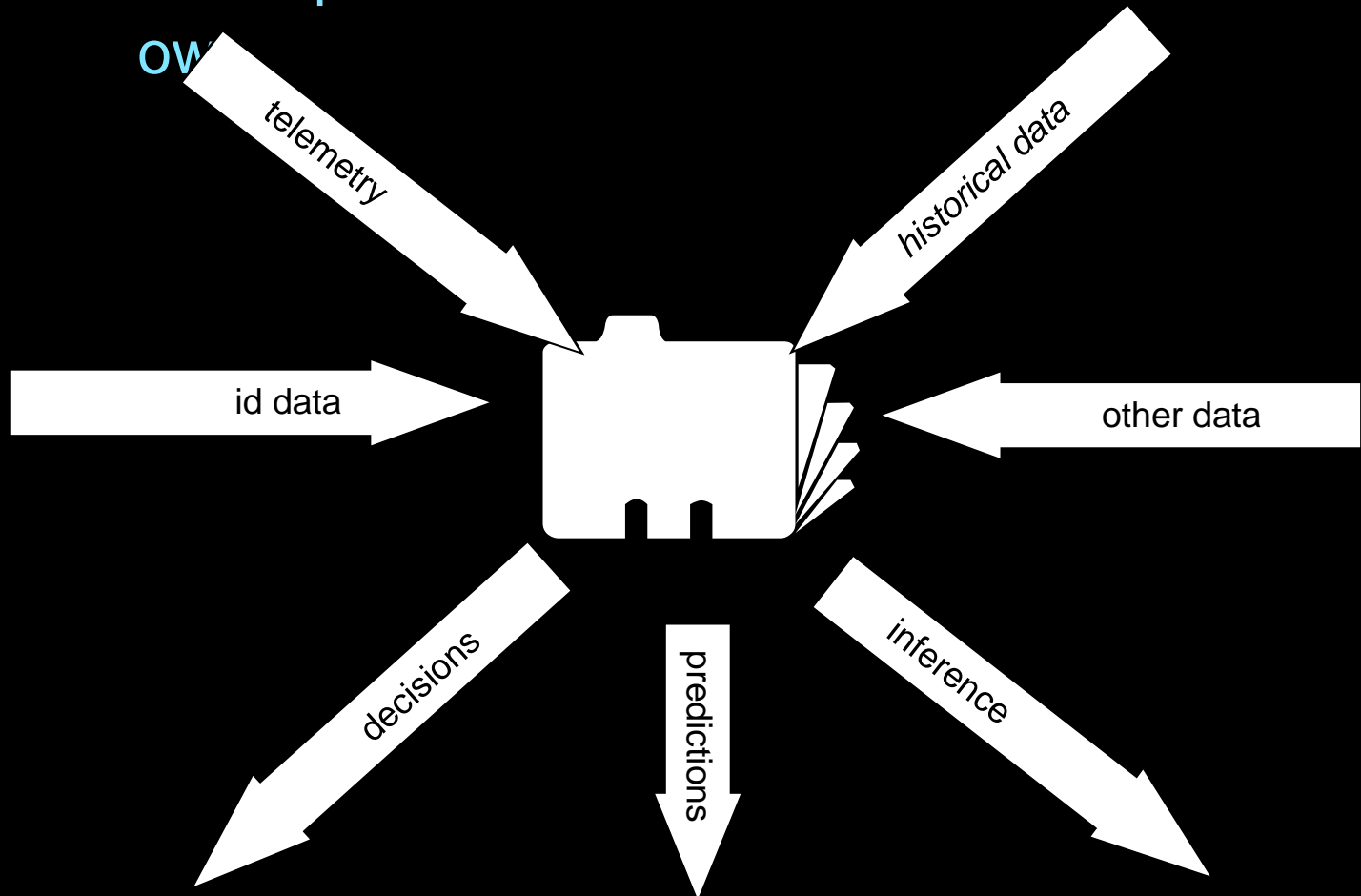



example applications

- What can you do with this technology ?

Supply chain benefits

- Reduce out of stocks, reduce inventory, speed up delivery, check freshness, track and trace, produce to demand, identify sources of diversion, identify counterfeiting, theft prediction, faster recalls

Consumer benefits

- Direct order from home, smart appliances, (e.g. microwave, washing machine, refrigerator), smart healthcare, assisted living

New and less expected benefits

- Customized products, smart recycling, checkout-less stores



the bull-whip effect

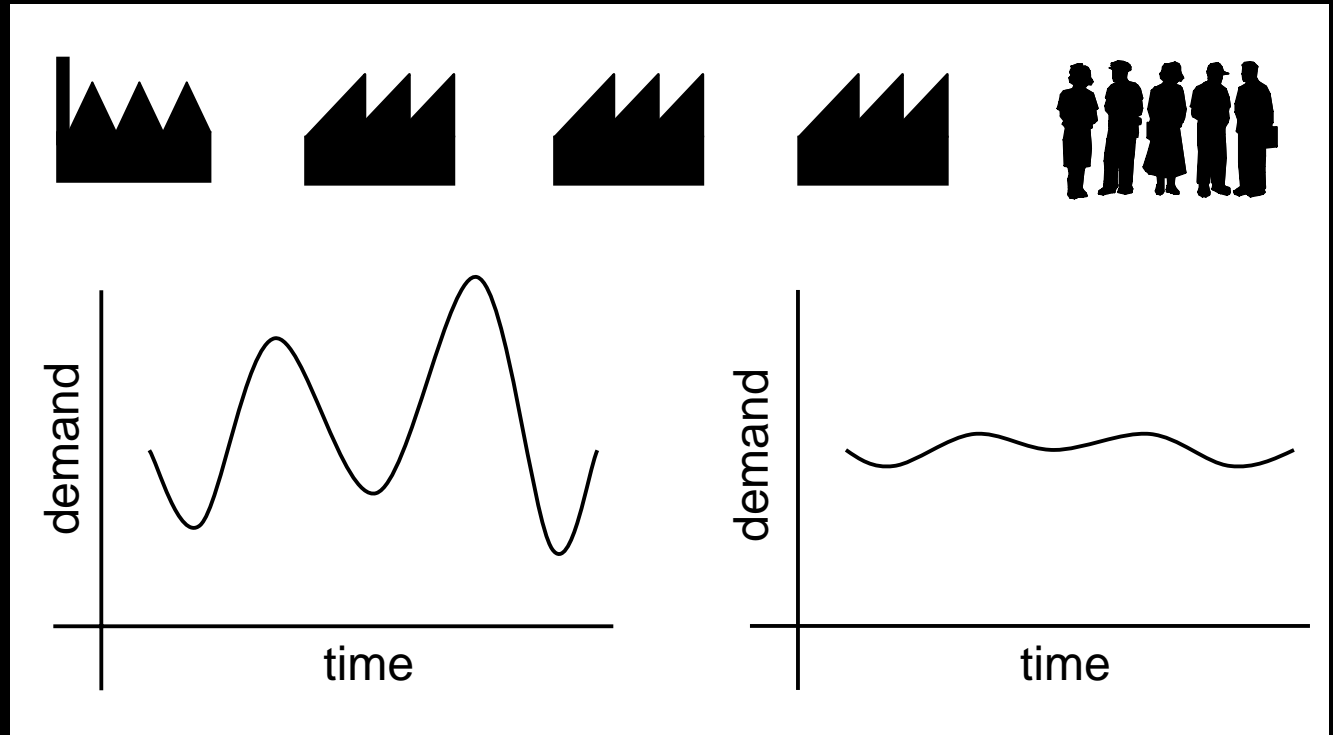



history

- P&G Pampers line observations
- J. Forrester
 - Industrial dynamics, MIT Press, Cambridge, MA, and Wiley, New York, 1961.
- J.D. Sterman
 - Modeling managerial behavior: Misperceptions of feedback in a dynamic decision making experiment, Manage Sci 35 (1989), 321-339
- H. Lee, P. Padmanabhan, and S. Whang
 - The bullwhip effect in supply chains, Sloan Management Review 38 (1997), 93-102.



the bull-whip in real life

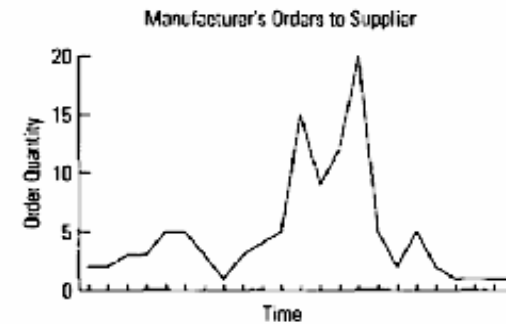
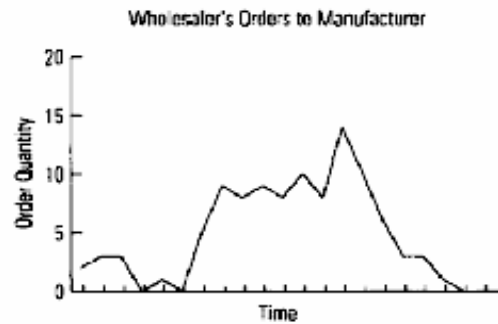
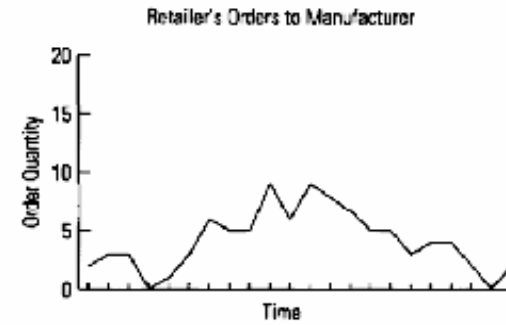



bull-whip in the beer game

RETAILER

WHOLESALER

DISTRIBUTOR

FACTORY

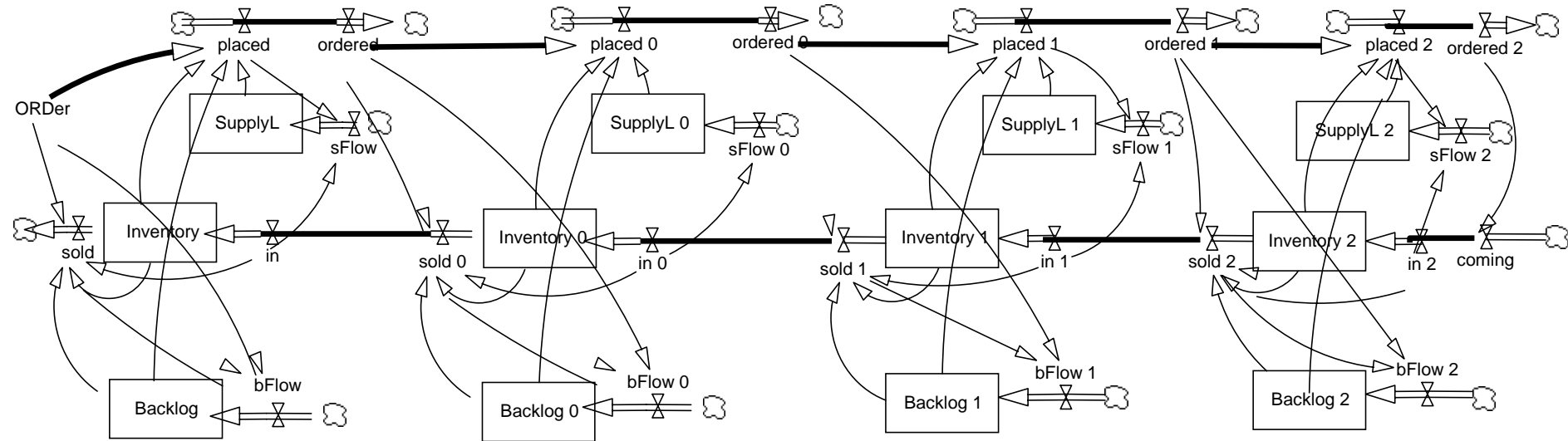



bull-whip in the beer game

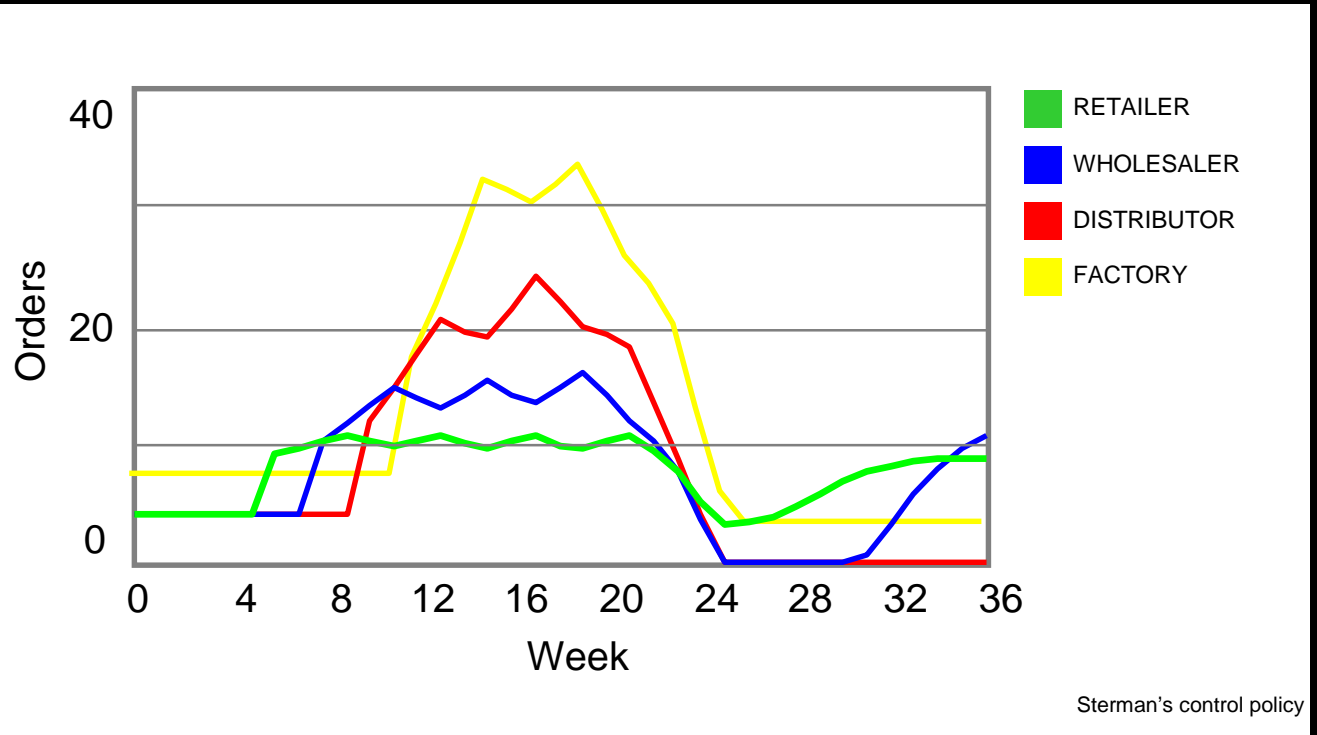



beer game with auto-id technology

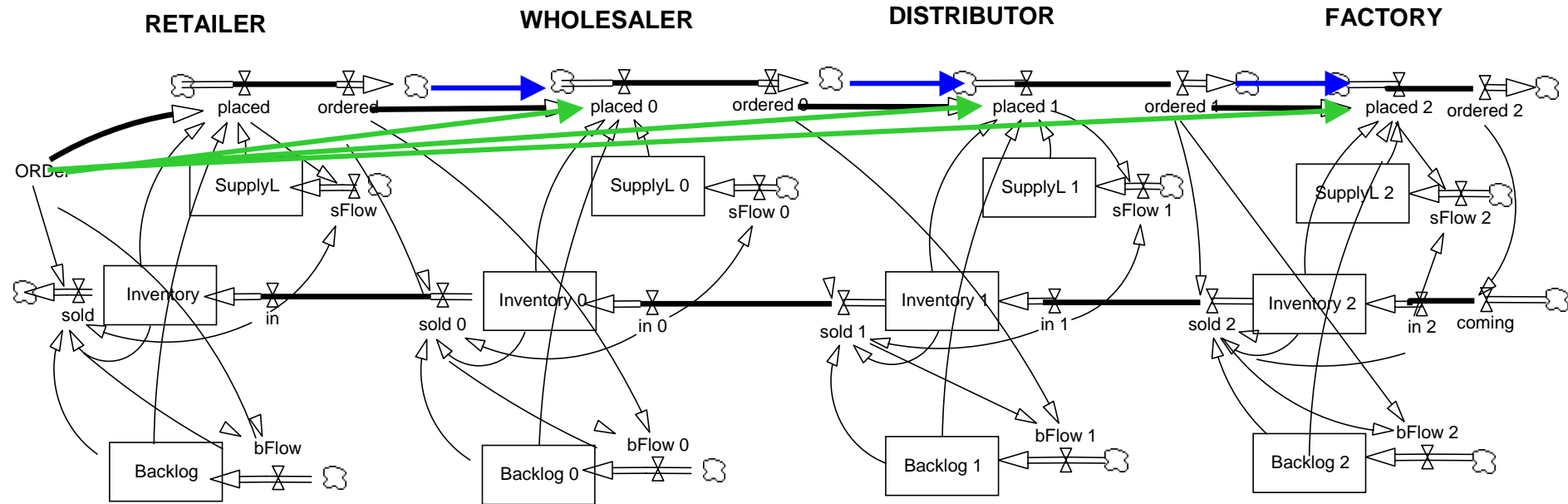



bull-whip with auto-id technology

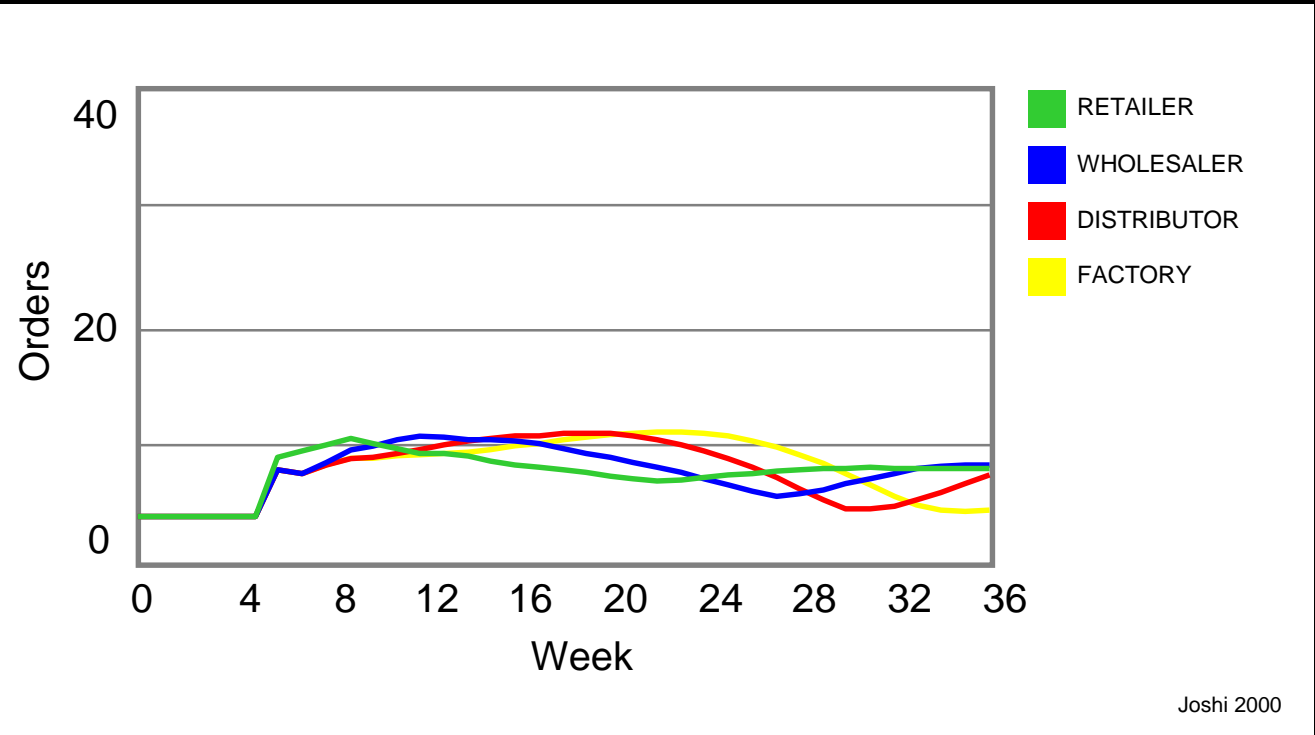



bull-whip today

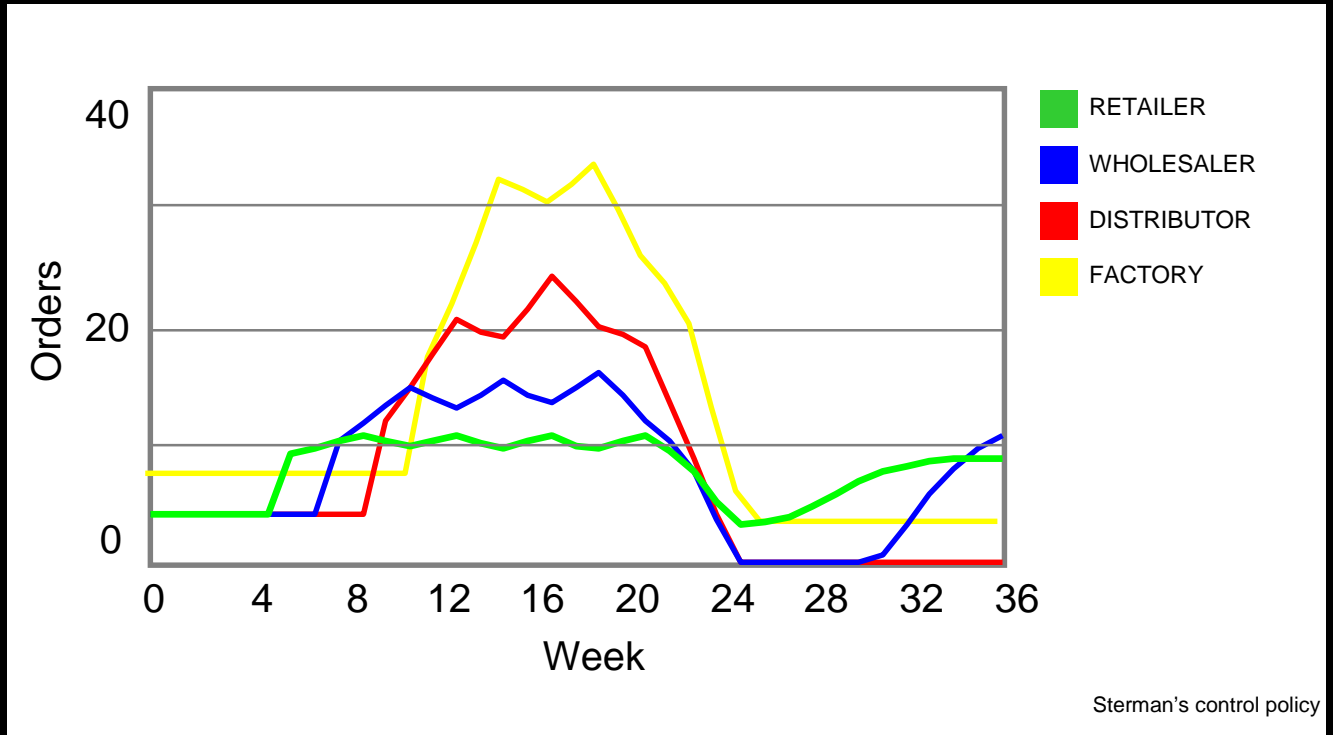



bull-whip with auto-id technology

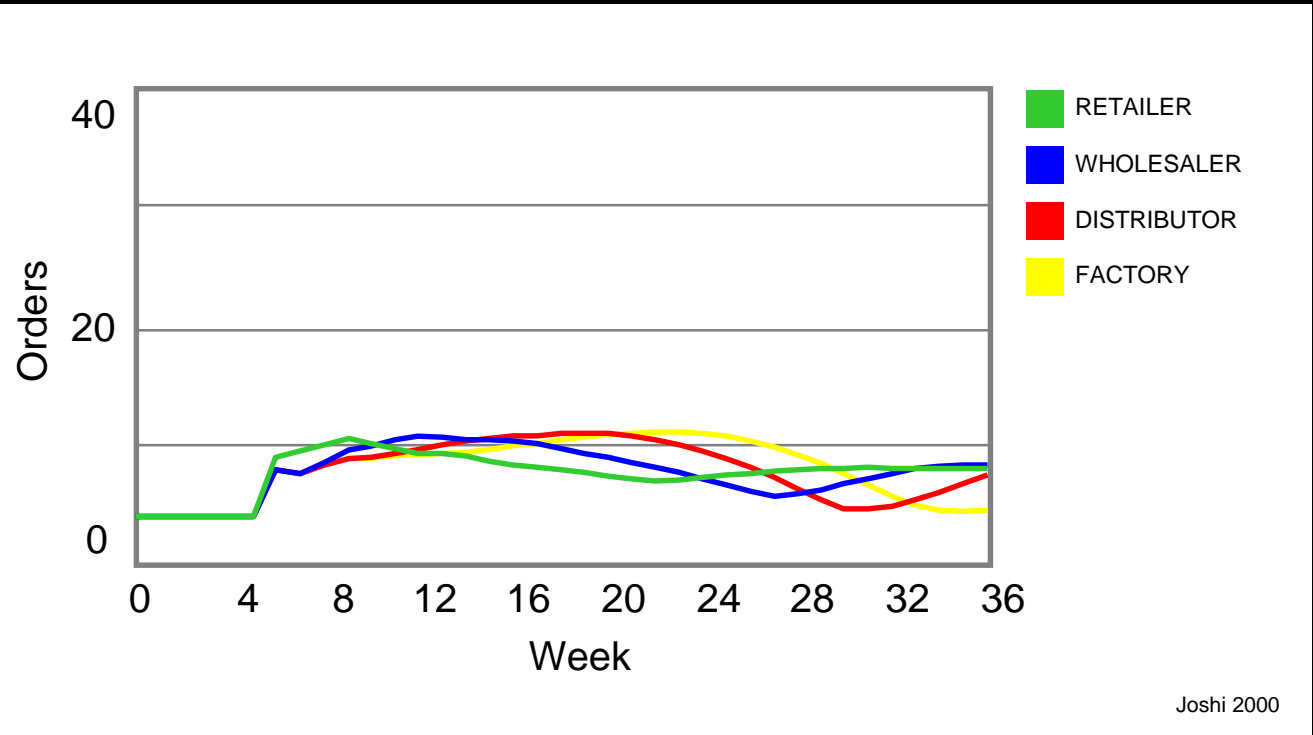



theft prediction

QuickTime™ and a
decompressor
are needed to see this picture.



consumer benefits





new and less expected benefits





timings

<u>1999</u>	October 1	P&G, Gillette, UCC Launch MIT Auto-ID Center
<u>2000</u>	Spring	First public demos at P&G CEO Roundtable MIT hosts Smart World forum to discuss technology
	Fall	Center expands to European University
<u>2001</u>	Fall	Auto-ID Center & sponsors place field trial
<u>2002</u>	Fall	Results and assessment of business case made public?
		Auto-ID Center publishes proposed tech. standard 1.0?
<u>2003-9</u>		Network effects, benefits, falling costs drive proliferation?



options for participation

- Sponsorship
 - end users - \$300,000 one time payment
 - vendors - \$150,000 for 3 years
- Non-profit trade bodies
 - free membership of EPC Alliance
- Other
 - web site
 - e-mail updates
 - conferences



contact

- <http://auto-id.mit.edu>
- e-mail: brooke@mit.edu