

GUIDELINES FOR DISPLAY

The following information is provided in order to assist you and your exhibit designer or installation/dismantle company in selecting space and preparing your exhibit booth for the NACS Show 2012. If you have additional questions regarding booth design, please contact NACS Exposition Staff at (703) 684-3600. PEI members should contact Bob Young at (918) 494-9696.

LINEAR BOOTH

Linear Booths, also called "in-line" booths, are generally arranged in a straight line and have neighboring exhibitors on their immediate right and left, leaving only one side exposed to the aisle. Dimensions for purposes of consistency and ease of layout and/or reconfiguration, floor plan design in increments of 10ft has become the de facto standard in the United States. Therefore, unless constricted by space or other limitations, Linear Booths are most commonly 10ft wide and 10ft deep, i.e. 10ft by 10ft. A maximum back wall height limitation of 8ft is generally specified.

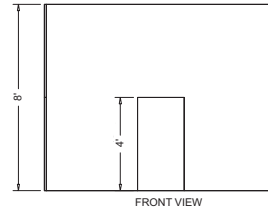
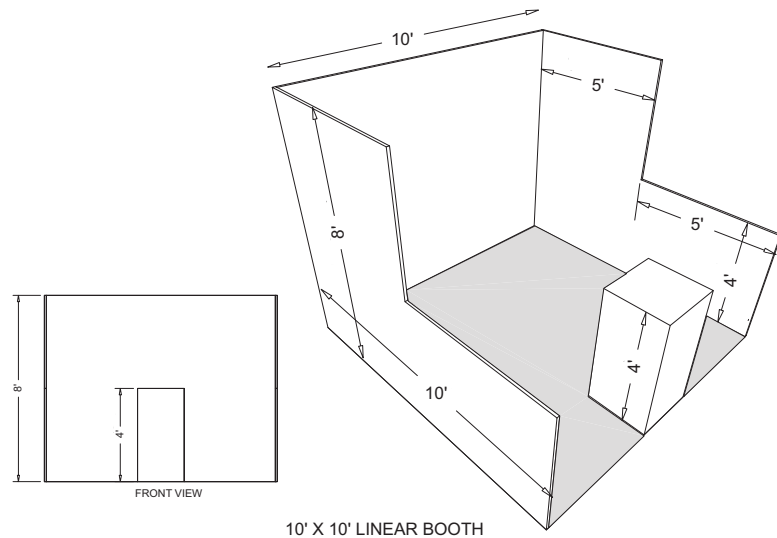

USE OF SPACE

Regardless of the number of Linear Booths utilized, e.g. 10ft by 20ft, 10ft by 30ft, 10ft by 40ft, etc. display materials should be arranged in such a manner so as not to obstruct sight lines of neighboring exhibitors. The maximum height of 8ft is allowed only in the rear half of the booth space, with a 4ft height restriction imposed on all materials in the remaining space forward to the aisle. (See Line-of-Sight exception to the right) Note: When three or more Linear Booths are used in combination as a single exhibit space, the 4ft height limitation is applied only to that portion of exhibit space which is within 10ft of an adjoining booth.

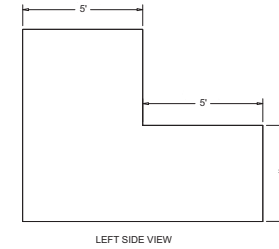
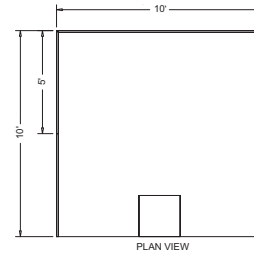

CORNER BOOTH

A Corner Booth is a Linear Booth at the end of a series of in-line booths with exposure to intersecting aisles on two sides. All other guidelines for Linear Booths apply.

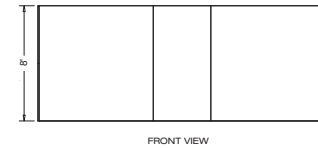
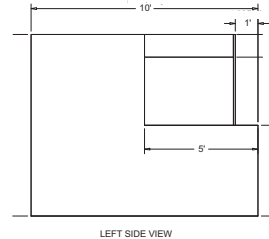

EXTENDED HEADER BOOTH

An Extended Header Booth is a Linear Booth 20ft or longer with a center extended header.

DIMENSIONS AND USE OF SPACE

All guidelines for Linear Booths apply to Extended Header Booths, except that the center extended header has a maximum height of 8ft, a maximum width of 20 percent of the length of the booth, and a maximum depth of 9ft from the back wall.

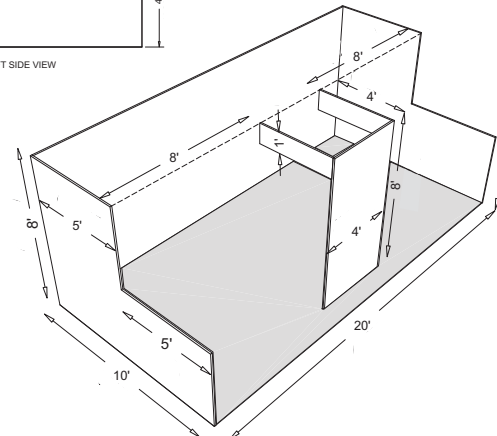
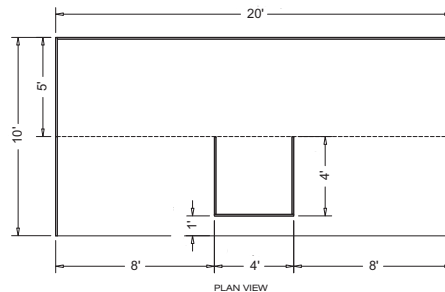

PERIMETER BOOTH

A Perimeter Booth is simply a Linear Booth that backs to a wall of the exhibit facility rather than to another exhibit.

DIMENSIONS AND USE OF SPACE

All guidelines for Linear Booths apply to Perimeter Booths except that the typical maximum backwall height is twelve feet (12').

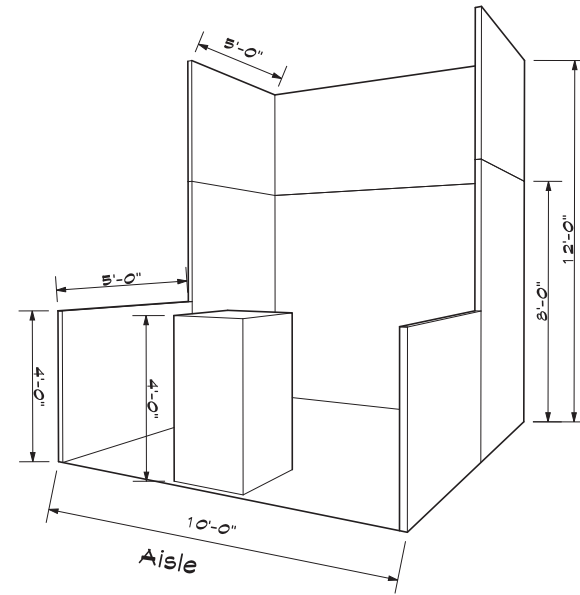
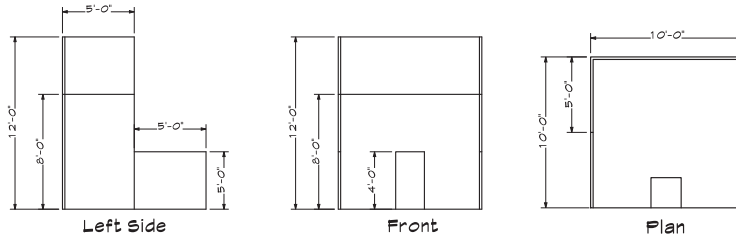

TENTS, CANOPIES AND CEILINGS

Canopies, including ceilings, umbrellas and canopy frames, can be either decorative or functional (such as to shade computer monitors from ambient light or for hanging products). Canopies for Linear or Perimeter Booths should comply with line of sight requirements (see "Guidelines for Linear or Perimeter Booths"). The bottom of the Canopy should not be lower than seven feet (7') from the floor within five feet (5') of any aisle. Canopy supports should be no wider than three inches (3"). This applies to any booth configuration that has a sightline restriction, such as a Linear Booth. Fire and safety regulations in many facilities strictly govern the use of canopies, ceilings and other similar coverings. Check with the appropriate local agencies prior to determining specific exhibition rules.

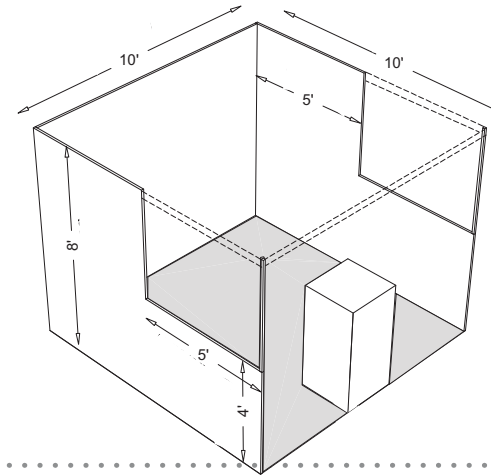

ISLAND BOOTH

An Island Booth is any size booth exposed to aisles on all four sides.

DIMENSIONS

An Island Booth is typically 20' x 20' or larger, although it may be configured differently.

USE OF SPACE

The entire cubic content of the space may be used up to the maximum allowable height, which is eighteen feet (18'). Hanging signs and graphics can be installed to a maximum height of twenty feet (20').

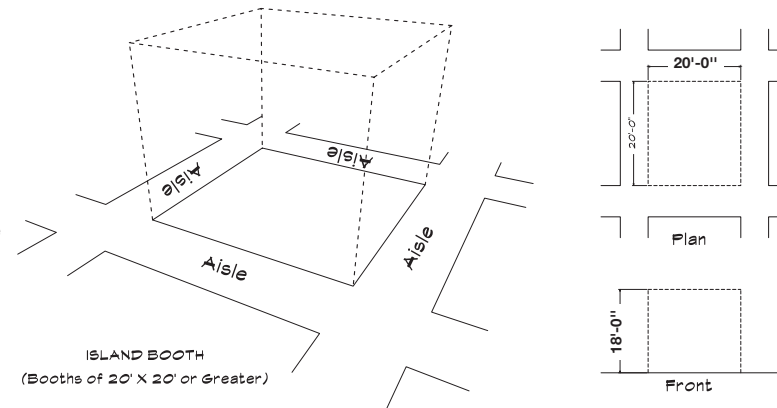

NACS SHOW GUIDELINES FOR DISPLAY (continued)

PENINSULA BOOTH

A Peninsula Booth is exposed to aisles on three (3) sides and composed of a minimum of four booths (20'x 20' minimum size). There are two types of Peninsula Booths: (a) one which backs up to Linear Booths; and (b) one which backs to another Peninsula Booth and is referred to as a "Split Island Booth."

DIMENSIONS

A Peninsula Booth is usually 20'x 20' or larger. When a Peninsula Booth backs up to two Linear Booths, the backwall is restricted to four feet (4') high within five feet (5') of each aisle, permitting adequate line of sight for the adjoining Linear Booths. Eighteen feet (18') is the maximum height allowance. (This guideline deviates from the IAEE revised 2009 Update.) Hanging signs and graphics can be installed to a maximum height of twenty feet (20').

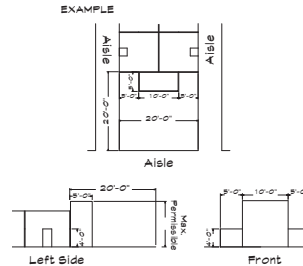
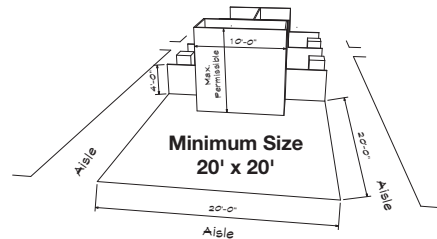

- ▶ **Maximum Theatrical/Lighting Truss Height:**
30 feet
- ▶ **Minimum Theatrical/Lighting Truss Height:**
24 feet
- ▶ Truss, lighting, speakers, and fixtures are not allowed to be installed outside the boundaries of the exhibit space.

HANGING SIGNS & GRAPHICS (ISLAND & PENINSULA BOOTHS ONLY)

Hanging signs and graphics are permitted in all standard Peninsula and Island Booths, to a maximum height of twenty feet (20'). All should comply with ordinary use-of-space requirements (for example, the highest point of any sign should not exceed the maximum allowable height for the booth type).

Hanging Signs & Graphics should be set back ten feet (10') from adjacent booths. Approval for the use of Hanging Signs & Graphics should be received from the exhibition organizer at least 60 days prior to installation (**by August 8, 2012**). Drawings should be available for inspection.

SPLIT ISLAND BOOTH

A Split Island Booth is a Peninsula Booth (20'x 20' or larger) which shares a common backwall with another Peninsula Booth (20'x 20' or larger). The entire cubic content of this booth may be used, up to the maximum allowable height, without any back wall line of sight restrictions. Eighteen feet (18') is the maximum height allowance. The entire cubic content of the space may be used up to the maximum allowable height. (This guideline deviates from the IAEE revised 2009 Update.) Hanging signs and graphics can be installed to a maximum height of twenty feet (20').

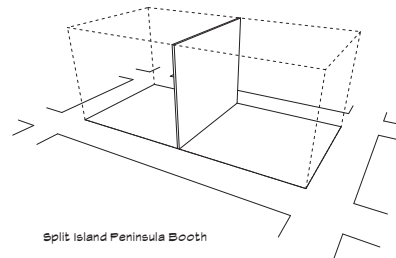

TOWERS

A Tower is a freestanding exhibit component separate from the main exhibit fixture. The height restriction is the same as that which applies to the appropriate exhibit configuration being used.

Towers in excess of eight feet (8') should have drawings available for inspection. Fire and safety regulations in many facilities strictly govern the use of towers. A building permit may be required.

MULTI-STORY EXHIBIT

A Multi-story Exhibit is a booth where the display fixtures exceed twelve feet (12'), including Double-decker and Triple-decker Booths. In many cities, a Multi-storied Exhibit requires prior approval by the exhibit facility and/or relevant local government agency because it is deemed to be a "structure" for building purposes. The city building department generally needs to issue a building permit based on an application and drawings prepared and submitted by a licensed architect or engineer. Exhibitors should obtain local building regulations early on to ensure that all time constraints are met. Exhibition organizers should be prepared to assist exhibitors in this application process.

Other Important Considerations

HANGING/LIGHTING TRUSS

Overhead truss with hanging signs or graphics must conform to the following guidelines. Truss may be rigged to 24 feet with hanging signage suspended below it to maximum height of 20 feet. No truss may exceed the outline of purchased exhibit space to hang over the public aisle space.

- ▶ **Maximum Truss Height:**
24 feet (from top of truss)
- ▶ **Maximum Hanging Sign/Graphic Height:**
20 feet (from top of signage)
- ▶ Truss, signage, and fixtures are not allowed to be installed outside the boundaries of the exhibit space.

THEATRICAL/AUDIO VISUAL LIGHTING TRUSSES

Theatrical and audio visual lighting trusses do not have hanging signage attached, and are used solely for theatrical lighting in the booth or audiovisual presentations.

All lighting and speakers should be directed to the inner confines of the booth space and should not project onto other exhibitors or show aisles. Fixtures or lighting that rotate, spin, pulsate, or any other special effects should not interfere with neighboring exhibitors, or detract from the overall atmosphere of the show.